



## **Purpose Built Parkour Facility**

### **Report by the Executive Head of Planning, Regeneration and Wellbeing**

#### **1.0 Summary**

- 1.1 This report advises the Cabinet Member of the proposed 'Purpose built Parkour Facility' which will use land on Monks Recreation Ground, which is owned by Lancing Parish Council and asks Cabinet to request Council to amend the Council's Capital Investment Programme (CIP) to include the scheme at a currently estimated value of £13,000 within the programme for the current financial year.

#### **2.0 Background and Proposals**

- 2.1 Parkour is a method of getting from A-B whilst over coming obstacles.
- 2.2 As the Cabinet Member may be aware, previous Parkour projects run by Adur and Worthing Council with local schools have been extremely popular, culminating in established Parkour groups being formed.
- 2.3 Adur and Worthing's Community Wellbeing Team, Urban Playground (a Sussex based Parkour group), Urban Rebound (Lancing's local group) and Lancing Parish Council met in 2010 to identify a suitable site to build a purpose built Parkour facility.
- 2.4 Monks Recreation ground was identified and permission was granted at Lancing Parish Council's committee meeting in January.
- 2.5 Urban Playground together with representatives from Urban Rebound met and the attached design was drawn up and agreed. Appendix 1. It is understood that there are no planning implications.
- 2.6 The scheme as shown on the attached appendix has been developed by the Council's Engineers and has been sent to tender. The cheapest quotation plus design costs etc brings the total costs in at approximately £13,000. This scheme, and hence the capital sum is not currently included within the Council's Capital Investment Programme and therefore in order to give the scheme a chance of progressing, it is necessary to seek the approval of Council to add this to the Capital Investment Programme.

2.7 Funding has been gained from the following sources - Viridor £7,500, Adur in Partnership £5,000, Lancing Parish Council £925 and Adur Parks have agreed to put up a 10% contingency if needed of £1,300.

2.8 If agreed, subject to the completion of contracts, works can start in June and will be completed in 3-4 weeks.

### **3.0 Financial Implications**

3.1 As long as the 10% contingency is not needed this scheme will have no initial financial implications for the Council, since £13,425.00 of funding has been gained.

3.2 Lancing Parish Council have committed to all ongoing maintenance and repair work on the facility.

### **4.0 Legal**

4.1 Section 19 of the Local Government (Miscellaneous Provisions) Act, 1976 empowers the Council to provide, inside or outside its area, such recreational facilities as it thinks fit and allows the Council to make a charge should it wish to do so.

The section also permits the Council to contribute by way of grant or loan towards the expenses incurred or to be incurred by any voluntary organisation in providing any recreational facilities which the authority has power to provide by virtue of this section; and by way of grant towards the expenses incurred or to be incurred by any other local authority in providing such facilities.

### **5.0 Recommendation**

**5.1 Cabinet Member is recommended to:-**

- (i) to include the scheme in the Council's Capital Investment Programme for the 2011-12 funded from external funding.**

**James Appleton**

Executive Head of Planning, Regeneration & Wellbeing

### **Local Government Act 1972**

#### **Background Papers:**

None.

#### **Contact Officer:**

Tammy Waine

Community Wellbeing Officer

Adur District Council

Civic Centre

Ham Road

01273 363319

[tammy.waine@adur-worthing.gov.uk](mailto:tammy.waine@adur-worthing.gov.uk)

## Schedule of Other Matters

### **1.0 Council Priority**

Matter considered no issues identified.

### **2.0 Specific Action Plans**

Matter considered no issues identified.

### **3.0 Sustainability Issues**

Matter considered no issues identified.

### **4.0 Equality Issues**

This scheme is entirely focused on improving provision for disabled children and youngsters.

### **5.0 Community Safety issues (Section 17)**

Matter considered no issues identified.

### **6.0 Human Rights Issues**

Matter considered no issues identified.

### **7.0 Reputation**

Matter considered no issues identified.

### **8.0 Consultations**

Matter considered no issues identified.

### **9.0 Risk assessment**

Matter considered no issues identified.

### **10.0 Health & Safety Issues**

Matter considered no issues identified.

### **11.0 Procurement Strategy**

Matter considered no issues identified.

### **12.0 Partnership working**

Matter considered no issues identified.



The Urban Playground Team  
Lancing Parkour Training Area  
(c) The Urban Playground Team 2010  
First Draft Design

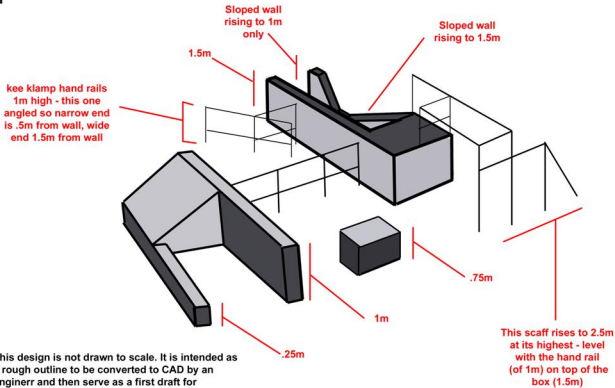

This design is not drawn to scale. It is intended as a rough outline to be converted to CAD by an engineer and then serve as a first draft for discussion and costings.